

**KODSAN**  
HOT WATER SYSTEMS



---

## PHA AIR SEPARATOR SET

---

Organize Sanayi Bölgesi Karamanlılar Cad. No: 10 - Sincan 06935 Ankara / TURKEY  
T. 90.312.267.07.67 - F. 90.312.267.05.54 - [www.kodsan.com.tr](http://www.kodsan.com.tr) - [info@kodsan.com.tr](mailto:info@kodsan.com.tr)



TYPE	Recommended Flow (m <sup>3</sup> /h)	Ø D (mm)	H' (mm)	Hf (mm)	Ø b	Flanged		Welded		Volume (lt)
						DN	Ff (mm)	Ø d	Fw (mm)	
KPH 50	10	165	680	330	1"	50	430	2"	330	10
KPH 65	15	165	680	330	1"	65	430	2 1/2"	330	10
KPH 80	20	219	810	365	1"	80	500	3"	400	22
KPH 100	30	219	810	365	1"	100	500	4"	400	23
KPH 125	50	323	1040	480	1"	125	625	5"	525	65
KPH 150	80	323	1040	480	1"	150	625	6"	525	66
KPH 200	100	400	1070	500	1"	200	775	8"	650	107
KPH 250	150	450	1220	580	1"	250	860	10"	720	162
KPH 300	200	500	1340	610	1"	300	910	12"	770	224

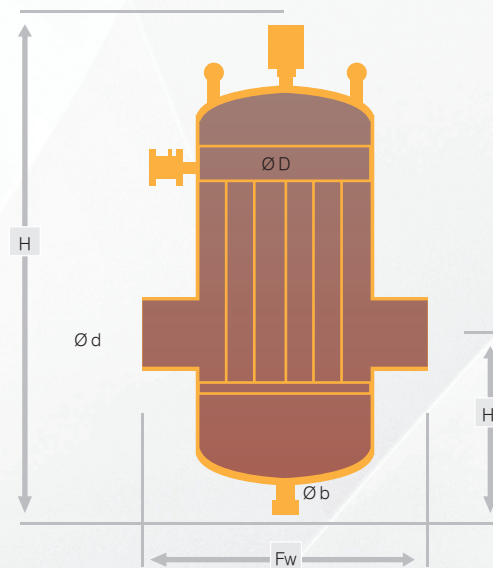
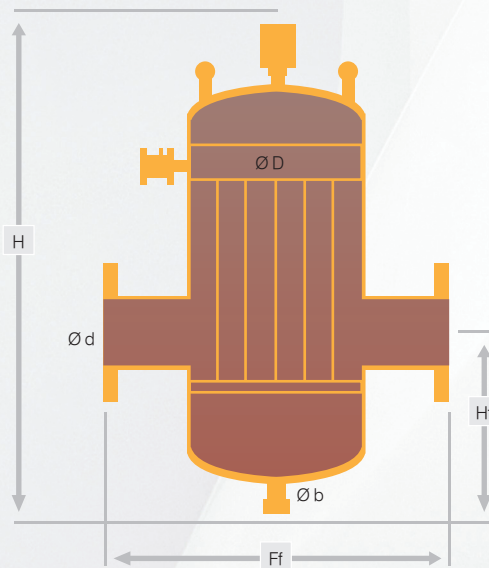

Elimination of air in a central heating system with proper techniques will increase the efficiency and life span of both complete system and individual components. Elimination of dirt and sediments in the water will also increase efficiency and life span. PHA Air Separator Set provides these functions within a single product and it saves both time and cost. PHA sets are available for systems from 2" to 12".

